



Is Now Part of



**ON Semiconductor®**

To learn more about ON Semiconductor, please visit our website at  
[www.onsemi.com](http://www.onsemi.com)

ON Semiconductor and the ON Semiconductor logo are trademarks of Semiconductor Components Industries, LLC dba ON Semiconductor or its subsidiaries in the United States and/or other countries. ON Semiconductor owns the rights to a number of patents, trademarks, copyrights, trade secrets, and other intellectual property. A listing of ON Semiconductor's product/patent coverage may be accessed at [www.onsemi.com/site/pdf/Patent-Marking.pdf](http://www.onsemi.com/site/pdf/Patent-Marking.pdf). ON Semiconductor reserves the right to make changes without further notice to any products herein. ON Semiconductor makes no warranty, representation or guarantee regarding the suitability of its products for any particular purpose, nor does ON Semiconductor assume any liability arising out of the application or use of any product or circuit, and specifically disclaims any and all liability, including without limitation special, consequential or incidental damages. Buyer is responsible for its products and applications using ON Semiconductor products, including compliance with all laws, regulations and safety requirements or standards, regardless of any support or applications information provided by ON Semiconductor. "Typical" parameters which may be provided in ON Semiconductor data sheets and/or specifications can and do vary in different applications and actual performance may vary over time. All operating parameters, including "Typicals" must be validated for each customer application by customer's technical experts. ON Semiconductor does not convey any license under its patent rights nor the rights of others. ON Semiconductor products are not designed, intended, or authorized for use as a critical component in life support systems or any FDA Class 3 medical devices or medical devices with a same or similar classification in a foreign jurisdiction or any devices intended for implantation in the human body. Should Buyer purchase or use ON Semiconductor products for any such unintended or unauthorized application, Buyer shall indemnify and hold ON Semiconductor and its officers, employees, subsidiaries, affiliates, and distributors harmless against all claims, costs, damages, and expenses, and reasonable attorney fees arising out of, directly or indirectly, any claim of personal injury or death associated with such unintended or unauthorized use, even if such claim alleges that ON Semiconductor was negligent regarding the design or manufacture of the part. ON Semiconductor is an Equal Opportunity/Affirmative Action Employer. This literature is subject to all applicable copyright laws and is not for resale in any manner.



# AN-6077

## SG6742 — Highly Integrated Green-Mode PWM Controller

### Abstract

This application note describes a detailed design strategy for a high-efficiency, compact flyback converter. Design considerations, mathematical equations, and guidelines for a Printed-Circuit-Board (PCB) layout are presented.

### Features

- High-Voltage Startup
- Low Operating Current: 2.7mA
- Linearly Decreasing PWM Frequency to 22KHz
- Frequency Hopping to Reduce EMI Emission
- Fixed PWM Frequency:  
ML and MR are 65KHz.  
HL and HR are 100KHz.
- Peak-Current-Mode Control
- Cycle-by-Cycle Current Limiting
- Leading-Edge Blanking (LEB)
- Synchronized Slope Compensation
- Internal Open-Loop Protection
- Gate Output Maximum Voltage Clamp: 18V
- V<sub>DD</sub> Under-Voltage Lockout (UVLO)
- V<sub>DD</sub> Over-Voltage Protection (OVP)
- Programmable Over-Temperature Protection (OTP)
- Internal Latch Circuit (OVP, OTP)
- Internal Sense Short-Circuit Protection
- Built-In Soft-Start Function  
ML and MR are 5ms.  
HL and HR are 6ms.
- Constant Power Limit (Full AC Input Range)
- Internal OTP Sensor with Hysteresis

### Applications

General-purpose, switch-mode power supplies and flyback power converters, including:

- Power Adapters
- Open-Frame Switch-Mode Power Supply (SMPS)

### Introduction

The highly integrated SG6742 series of PWM controllers provides several features to enhance the performance of flyback converters.

To minimize standby power consumption, a proprietary green-mode function provides off-time modulation to linearly decrease the switching frequency at light-load conditions. To avoid acoustic-noise problems, the minimum PWM frequency is set above 22KHz. This green-mode function enables the power supply to meet international power conservation requirements. With the internal high-voltage startup circuitry, the power loss due to bleeding resistors is also eliminated. To further reduce power consumption, SG6742 is manufactured using the BiCMOS process, which allows an operating current of only 2.7mA.

Built-in synchronized slope compensation achieves stable peak-current-mode control. The proprietary external line compensation ensures a constant output-power limit over a wide AC input voltage range, from 90V<sub>AC</sub> to 264V<sub>AC</sub>.

SG6742 provides many protection functions. In addition to cycle-by-cycle current limiting, the internal open-loop protection circuit ensures safety should an open-loop or output short-circuit failure occur.

	OVP (VDD)	OLP (FB)	OTP (RT)	SCP (SENSE)	Frequency
SG6742ML	Latch	Latch	Latch	Auto Restart	65KHz
SG6742MR	Latch	Auto Restart	Latch	Auto Restart	65KHz
SG6742HL	Latch	Latch	Latch	Auto Restart	100KHz
SG6742HR	Latch	Auto Restart	Latch	Auto Restart	100KHz

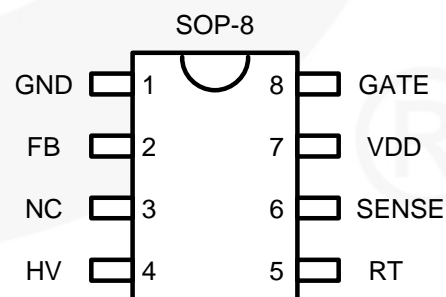

Figure 1. Pin Configuration (Top View)

# Typical Application

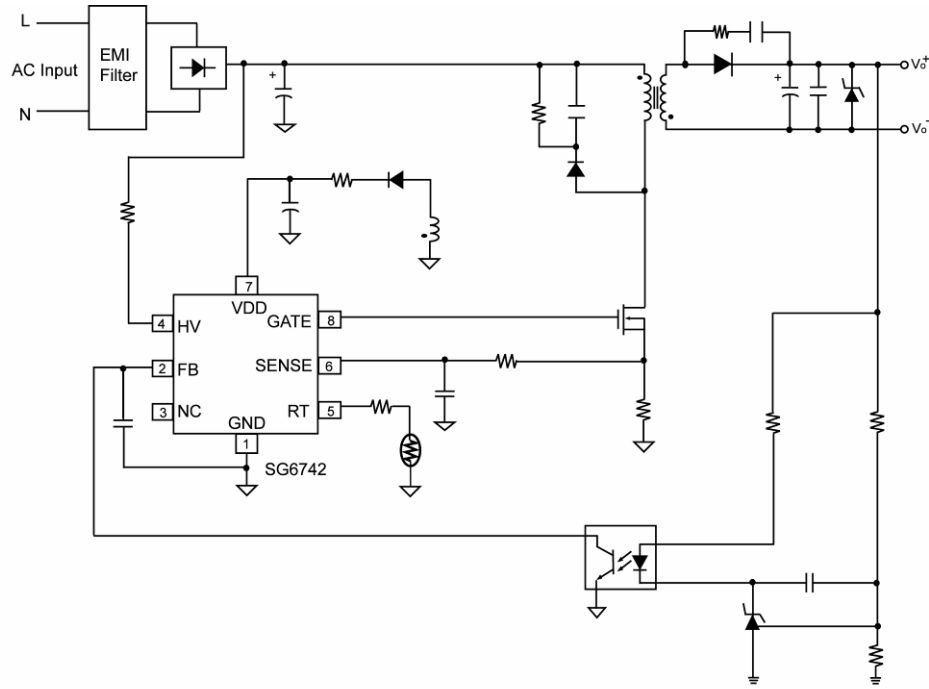

Figure 2. Typical Application

# Block Diagram

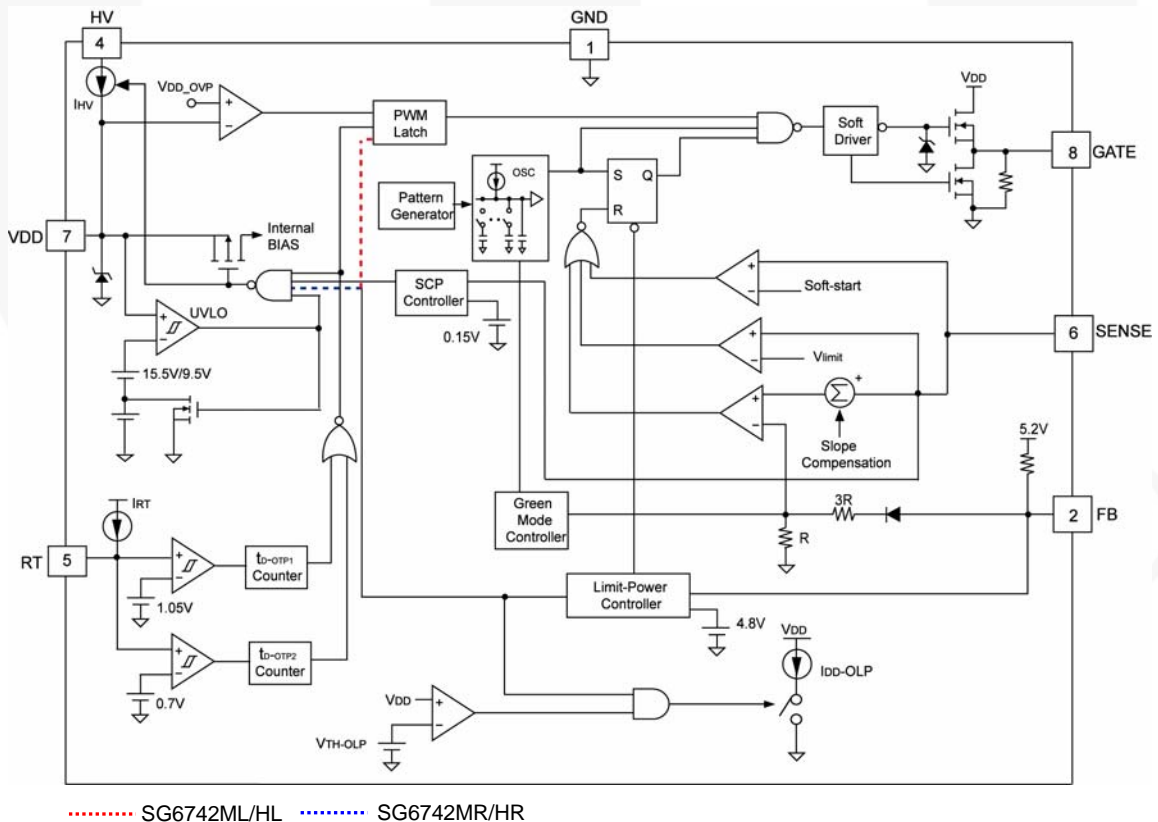

Figure 3. Functional Block Diagram

# Internal Block Operation

## Startup Circuitry

When the power is turned on, the internal current source (typically 2mA) charges the hold-up capacitor  $C_1$  through a startup resistor  $R_{HV}$ . During the startup sequence, the  $V_{BULK}$  provides a startup current of about 2.3mA and charges the  $V_{DD}$  capacitor  $C_1$ .  $R_{HV}$  and D2 are series connections and can be directly connected by  $V_{AC}$  to the HV pin. As the VDD pin reaches the start threshold voltage  $V_{DD-ON}$ , the SG6742 activates and signals the MOSFET. The high-voltage source current is switched off and the supply current is drawn from the auxiliary winding of the main transformer, as shown in Figure 4.

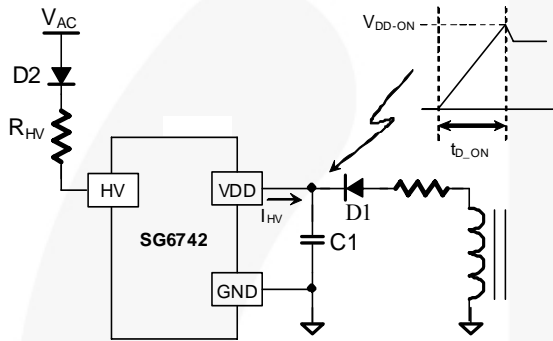

Figure 4. Startup Circuit for Power Transfer

When the supply current is drawn from the transformer, it draws a leakage current of about  $1\mu A$  from the HV pin. The maximum power dissipation of the  $R_{HV}$  is:

$$P_{R_{HV}} = I_{HV-LC(Typ.)}^2 \times R_{HV} \tag{1}$$

where  $I_{HV-LC}$  is the supply current drawn from HV pin.

$$P_{R_{HV}} = 1\mu A^2 \times 100K\Omega \cong 0.1\mu W \tag{2}$$

## Soft-Start

For many applications, it is necessary to minimize the inrush current during the startup period. The built-in 5ms/6ms soft-start circuit significantly reduces the startup current spike and output-voltage overshoot.

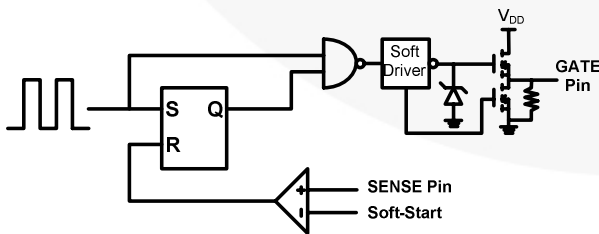

Figure 5. Soft-Start Circuit

## Under-Voltage Lockout (UVLO)

The SG6742 has a voltage detector on the VDD pin to ensure that the chip has enough power to drive the MOSFET. Figure 6 shows a hysteresis of the turn-on and turn-off threshold levels and an open-loop-release voltage.

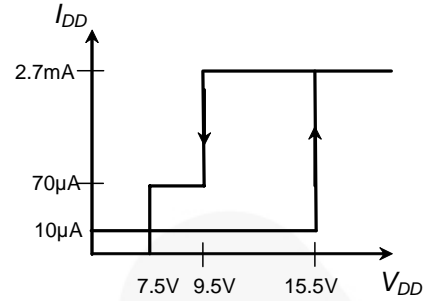

Figure 6. UVLO Specification

The turn-on and turn-off thresholds are internally fixed at 15.5V and 9.5V. During startup, the  $V_{DD}$  capacitor must be charged to 15.5V to enable the IC. The capacitor continues to supply the  $V_{DD}$  until the energy can be delivered from the auxiliary winding of the main transformer. The  $V_{DD}$  must not drop below 9.5V during startup.

If the secondary output short circuits or the feedback loop is open, the FB pin voltage rises rapidly toward the open-loop voltage,  $V_{FB-OPEN}$ . If the FB voltage remains above  $V_{FB-OLP}$  and lasts for  $t_{D-OLP}$ , the SG6742 stops emitting output pulses and enters latched-up mode until  $V_{DD}$  drops below 5V. To further limit the input power under a short-circuit or open-loop condition, a special two-step UVLO mechanism prolongs the discharge time of the  $V_{DD}$  capacitor. Figure 7 shows the traditional UVLO method, along with the special two-step UVLO method. In the two-step UVLO mechanism, an internal sinking current,  $I_{DD-OLP}$ , pulls the  $V_{DD}$  voltage toward the  $V_{DD-OLP}$ . This sinking current is disabled after the  $V_{DD}$  drops below  $V_{DD-OLP}$ ; after which, the  $V_{DD}$  voltage is again charged towards  $V_{DD-ON}$ . With the two-step UVLO mechanism, the average input power during a short-circuit or open-loop condition is greatly reduced. As a result, overheating does not occur.

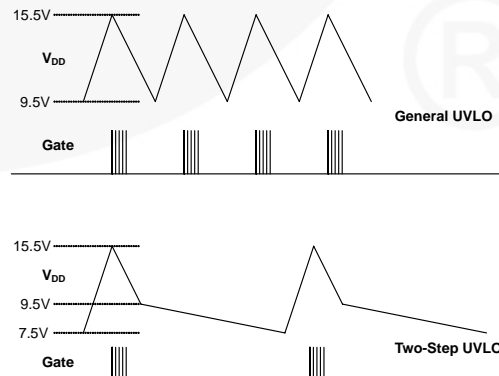

Figure 7. UVLO Effect

## FB Input

The SG6742 is designed for peak-current-mode control. A current-to-voltage conversion is accomplished externally with current-sense resistor  $R_S$ . Under normal operation, the FB level controls the peak inductor current:

$$I_{PEAK} = \frac{V_{FB} - 0.6}{4 \times R_S} \quad (3)$$

where  $V_{FB}$  is the voltage on the FB pin and 4 is an internal divider ratio.

When  $V_{FB}$  is less than 0.6V, the SG6742 terminates the output pulses.

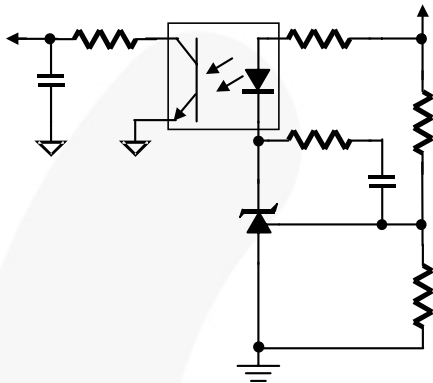

Figure 8. Feedback Circuit

Figure 8 is a typical feedback circuit consisting mainly of a shunt regulator and an opto-coupler.  $R_1$  and  $R_2$  form a voltage divider for the output-voltage regulation.  $R_3$  and  $C_1$  are adjusted for control-loop compensation. A small-value RC filter (e.g.  $R_{FB} = 47\Omega$ ,  $C_{FB} = 1nF$ ) placed on the FB pin to the GND can further increase the stability. The maximum sourcing current of the FB pin is 1.5mA. The phototransistor must be capable of sinking this current to pull the FB level down at no load. The value of the biasing resistor  $R_b$  is determined as follows:

$$\frac{V_{OUT} - V_D - V_Z}{R_b} \cdot K \geq 1.5mA \quad (4)$$

where:

$V_D$  is the drop voltage of photodiode, approximately 1.2V;

$V_Z$  is the minimum operating voltage, 2.5V of the shunt regulator; and

$K$  is the current transfer rate (CTR) of the opto-coupler.

For an output voltage  $V_{OUT} = 5V$ , with  $CTR = 100\%$ , the maximum value of  $R_b$  is 860 $\Omega$ .

## Built-In Slope Compensation

A flyback converter can be operated in either Discontinuous-Current Mode (DCM) or Continuous-Current Mode (CCM). There are many advantages when operating the converter in CCM. With the same output power, a converter in CCM exhibits a smaller peak inductor current than one in DCM. Therefore, a small-sized transformer and a low-rated MOSFET can be applied. On the secondary side of the transformer, the RMS output current of DCM can be twice that of CCM. Larger wire gauge and output capacitors with larger ripple-current ratings are required. DCM operation also results in a higher output voltage spike. A large LC filter is added. Therefore, a flyback converter in CCM achieves better performance with lower component cost.

Despite the above advantages of CCM operation, there is one concern—stability. In CCM operation, the output power is proportional to the average inductor current, while the peak current remains controlled. This causes sub-harmonic oscillation when the PWM duty cycle exceeds 50%. Adding slope compensation (reducing the current-loop gain) is an effective way to prevent oscillation. The SG6742 introduces a synchronized positive-going ramp ( $V_{SLOPE}$ ) in every switching cycle to stabilize the current loop. Therefore, SG6742 helps design a cost-effective, highly efficient, compact, flyback power supply that operates in CCM without additional external components.

The positive ramp added is:

$$V_{SLOPE} = V_{SL} \cdot D \quad (5)$$

where  $V_{SL} = 0.33V$  and  $D = \text{duty cycle}$ .

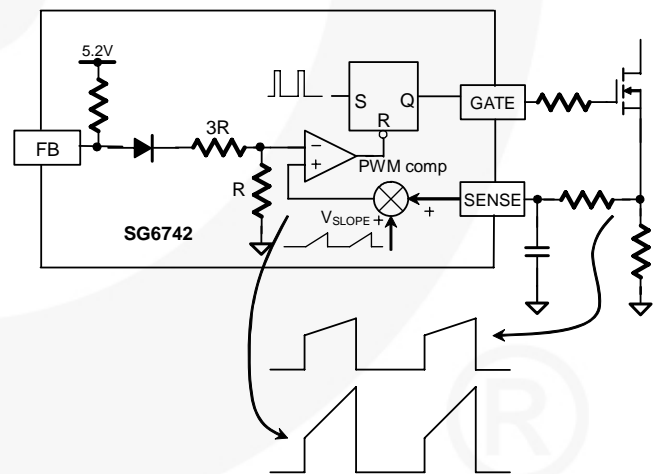

Figure 9. Synchronized Slope Compensation

## Constant Output-Power Limit

The maximum output power of a flyback converter can generally be determined from the current-sense resistor  $R_S$ . When the load increases, the peak inductor current increases accordingly. When the output current arrives at the protection value, the Output-Current-Protection (OCP) comparator dominates the current-control loop. OCP occurs when the current-sense voltage reaches the threshold value. The output GATE driver is turned off after a small propagation delay  $t_{PD}$ . The delay time results in unequal power-limit levels under universal input. A sawtooth power limiter (saw limiter) is designed to solve the unequal power limit problem. As shown in Figure 10, the saw limiter is designed as a positive ramp signal ( $V_{\text{limit\_ramp}}$ ) and is fed into the inverting input of the OCP comparator. This results in a lower current limit at high-line inputs than at low-line inputs. However, with the fixed propagation delay  $t_{PD}$ , the peak primary current would be the same for various line-input voltages. Therefore, the maximum output power can remain a constant value within a wide input voltage range without adding any external circuitry.

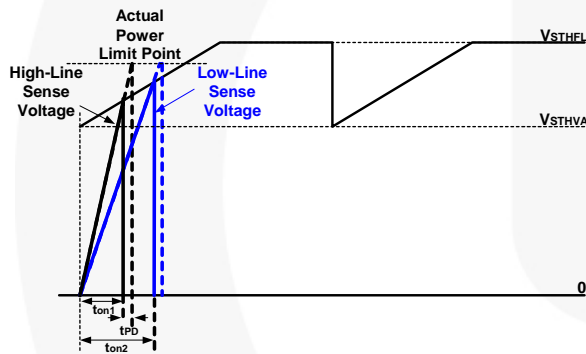

Figure 10. Constant Power-Limit Compensation

## Leading-Edge Blanking (LEB)

A voltage signal proportional to the MOSFET current develops on the current-sense resistor  $R_S$ . Each time the MOSFET is turned on, a spike induced by the diode reverse recovery and the output capacitances of the MOSFET and diode, appears on the sensed signal. A leading-edge blanking time of about 140ns is introduced to avoid premature termination of the MOSFET by the spike. Therefore, only a small-value RC filter (e.g.  $100\Omega + 470\text{pF}$ ) is required between the SENSE pin and  $R_S$ . Still, a non-inductive resistor for the  $R_S$  is recommended.

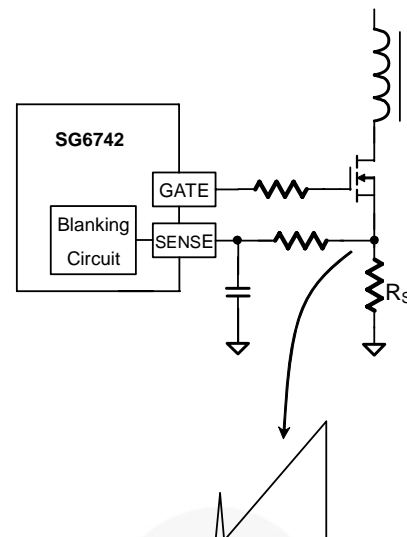

Figure 11. Circuit for Brownout

## Sense-Pin Short-Circuit Protection

The SG6742 provides safety protection for power supply production. When the sense resistor is shorted by soldering during production, the pulse-by-pulse current limiting loses efficiency for the purpose of providing over-power protection for the unit. The unit may be damaged when the loading is larger than the original maximum load. To protect against a short circuit across the current-sense resistor, the controller is designed to immediately shut down if a continuously low voltage (around  $0.15\text{V}/150\mu\text{s}$ ) on the Sense pin is detected.

## Open-Loop Protection (OLP)

The SG6742 contains the open loop protection function. If the output load is higher than the maximum output current, the output voltage will drop and the feedback error amplifier will be saturated. Once the FB voltage trips the OLP threshold  $4.8\text{V}$  and keeps longer than  $56\text{ms}$ , the protection will be activated to turn off the gate output to stop the switching of power circuit. As shown in Figure 12, the FB voltage is compared with  $4.8\text{V}$  reference voltage. If the FB voltage is higher than  $4.8\text{V}$ , the OLP timer starts counting. If the OLP condition persists for  $56\text{ms}$ , the timer generates the OLP signal and acts as auto restart for SG6742MR/HR, latch off for SG6742ML/HL. Moreover, this protection will be reset after IC's UVLO.

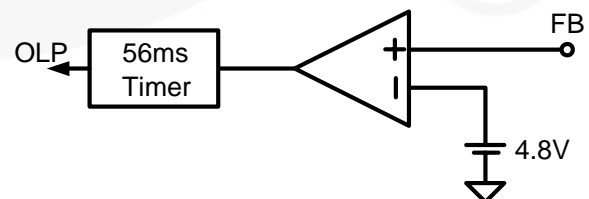

Figure 12. Open-Loop Protection Circuit

## Output Driver / Soft Driving

The output stage is a fast totem-pole gate driver capable of directly driving an external MOSFET. An internal Zener diode clamps the driver voltage under 18V to protect the MOSFET against over-voltage. By integrating special circuits to control the slew rate of switch-on rising time, the external resistor  $R_G$  may not be necessary to reduce switching noise, improving Electromagnetic Interference (EMI) performance.

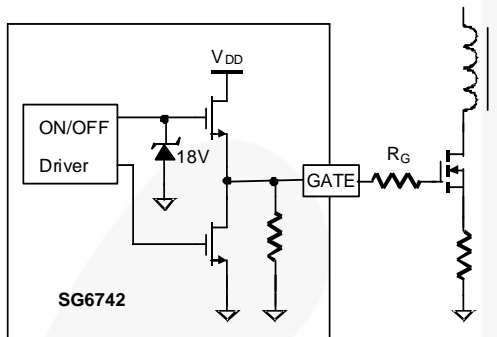

Figure 13. Gate Driver

## Thermal Protection

A constant current  $I_{RT}$  ( $I_{RT} = 100\mu A$ ) is provided from the RT pin. For over-temperature protection, an NTC thermistor  $R_T$  in series with a resistor  $R_a$  can be connected between the RT pin and ground. When  $V_{RT}$ , the voltage level of the RT pin, is less than 1.05V; PWM output is latched off after a debounce time of  $t_{D-OTP1}$ , which is added to prevent false triggering. If  $V_{RT}$  is less than 0.7V, PWM output latches off after a very short debounce time of  $t_{D-OTP2}$ .

If the thermal protection is not used, connect a small capacitor (around 0.47nF is recommended) from the RT pin to the GND pin to prevent noise interference. This RT capacitor cannot be larger than 1nF or the thermal protection is triggered before a successful startup of output voltage.

## Over-Temperature Protection (OTP)

The built-in temperature-sensing circuit shuts down PWM output once the junction temperature exceeds 135°C. While PWM output is shut down,  $V_{DD}$  gradually drops to the UVLO voltage (around 7.5V). Then  $V_{DD}$  charges up to the startup threshold voltage of 15.5V through the startup resistor until PWM output is restarted. This hiccup-mode protection occurs repeatedly as long as the temperature remains above 130°C. The temperature hysteresis window for the OTP circuit is 25°C.

## Printed Circuit Board Layout

Current, voltage, and switching frequency make PCB layout and design very important. Good PCB layout minimizes excessive EMI and prevents the power supply from being disrupted during surge/ESD tests. The following are some general guidelines:

- For better EMI performance and to reduce line frequency ripples, the output of the bridge rectifier should be connected to capacitor  $C_{\text{bulk}}$  first, then to switching circuits.
- The high-frequency current loop is found in the loop  $C_{\text{bulk}} - \text{Transformer} - \text{MOSFET} - R_s - C_{\text{bulk}}$  in Figure 14. The area enclosed by this current loop should be as small as possible. Keep the traces (especially 4→1) short, direct, and wide. High-voltage drain traces related to the MOSFET and RCD snubber should be kept far from control circuits to prevent unnecessary interference. If a heatsink is used for the MOSFET, grounding the heatsink is recommended.
- As indicated by 3 in Figure 14, the control circuits' ground should be connected first, then to other circuitry.
- As indicated by 2 in Figure 14, the area enclosed by the **transformer auxiliary winding,  $D_1$ , and  $C_1$**  should also be kept small. Place  $C_1$  close to the SG6742 for good decoupling.

Two suggestions with pros and cons for ground connections are recommended.

- $\text{GND}3 \rightarrow 2 \rightarrow 4 \rightarrow 1$ : Possible method for circumventing the sense signals and common impedance interference.
- $\text{GND}3 \rightarrow 2 \rightarrow 1 \rightarrow 4$ : Potentially better for ESD testing where a ground is not available for the power supply. The charges for ESD discharge path go from secondary through the transformer stray capacitance to the  $\text{GND}2$  first. Then, the charges go from  $\text{GND}2$  to  $\text{GND}1$  and back to the mains. It should be noted that control circuits should not be placed on the discharge path. Point discharge for common choke can decrease high-frequency impedance and help increase ESD immunity.
- Should a Y-cap between primary and secondary be required, the Y-cap should be connected to the **positive terminal of the  $C_{\text{bulk}}$  ( $V_{\text{DC}}$ )**. If this Y-cap is connected to the primary GND, it should be connected to the **negative terminal of the  $C_{\text{bulk}}$  ( $\text{GND}1$ )** directly. Point discharge of the Y-cap also helps with ESD. However, according to safety requirements, the creepage between the two pointed ends should be at least 5mm.

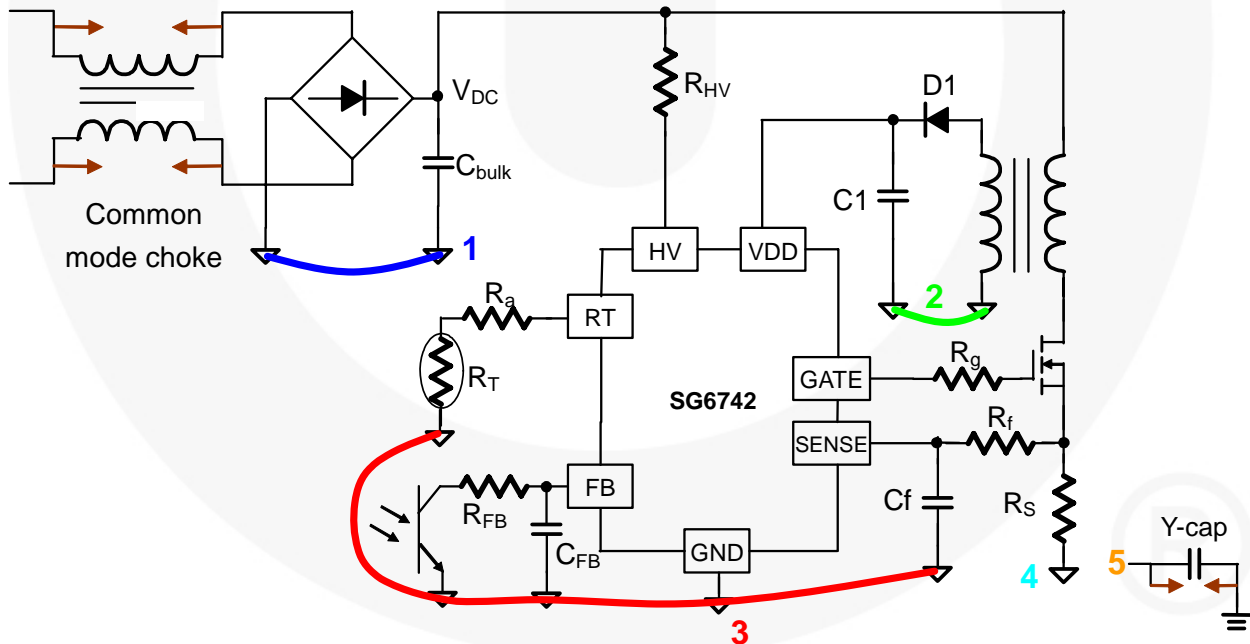

Figure 14. Layout Considerations



## Related Datasheets

[SG6742ML/MR — Highly Integrated Green-Mode PWM Controller](#)

[SG6742HL/HR — Highly Integrated Green-Mode PWM Controller](#)

---

### DISCLAIMER

FAIRCHILD SEMICONDUCTOR RESERVES THE RIGHT TO MAKE CHANGES WITHOUT FURTHER NOTICE TO ANY PRODUCTS HEREIN TO IMPROVE RELIABILITY, FUNCTION, OR DESIGN. FAIRCHILD DOES NOT ASSUME ANY LIABILITY ARISING OUT OF THE APPLICATION OR USE OF ANY PRODUCT OR CIRCUIT DESCRIBED HEREIN; NEITHER DOES IT CONVEY ANY LICENSE UNDER ITS PATENT RIGHTS, NOR THE RIGHTS OF OTHERS.

### LIFE SUPPORT POLICY

FAIRCHILD'S PRODUCTS ARE NOT AUTHORIZED FOR USE AS CRITICAL COMPONENTS IN LIFE SUPPORT DEVICES OR SYSTEMS WITHOUT THE EXPRESS WRITTEN APPROVAL OF THE PRESIDENT OF FAIRCHILD SEMICONDUCTOR CORPORATION.

As used herein:

1. Life support devices or systems are devices or systems which, (a) are intended for surgical implant into the body, or (b) support or sustain life, or (c) whose failure to perform when properly used in accordance with instructions for use provided in the labeling, can be reasonably expected to result in significant injury to the user.
2. A critical component is any component of a life support device or system whose failure to perform can be reasonably expected to cause the failure of the life support device or system, or to affect its safety or effectiveness.

ON Semiconductor and  are trademarks of Semiconductor Components Industries, LLC dba ON Semiconductor or its subsidiaries in the United States and/or other countries. ON Semiconductor owns the rights to a number of patents, trademarks, copyrights, trade secrets, and other intellectual property. A listing of ON Semiconductor's product/patent coverage may be accessed at [www.onsemi.com/site/pdf/Patent-Marking.pdf](http://www.onsemi.com/site/pdf/Patent-Marking.pdf). ON Semiconductor reserves the right to make changes without further notice to any products herein. ON Semiconductor makes no warranty, representation or guarantee regarding the suitability of its products for any particular purpose, nor does ON Semiconductor assume any liability arising out of the application or use of any product or circuit, and specifically disclaims any and all liability, including without limitation special, consequential or incidental damages. Buyer is responsible for its products and applications using ON Semiconductor products, including compliance with all laws, regulations and safety requirements or standards, regardless of any support or applications information provided by ON Semiconductor. "Typical" parameters which may be provided in ON Semiconductor data sheets and/or specifications can and do vary in different applications and actual performance may vary over time. All operating parameters, including "Typicals" must be validated for each customer application by customer's technical experts. ON Semiconductor does not convey any license under its patent rights nor the rights of others. ON Semiconductor products are not designed, intended, or authorized for use as a critical component in life support systems or any FDA Class 3 medical devices or medical devices with a same or similar classification in a foreign jurisdiction or any devices intended for implantation in the human body. Should Buyer purchase or use ON Semiconductor products for any such unintended or unauthorized application, Buyer shall indemnify and hold ON Semiconductor and its officers, employees, subsidiaries, affiliates, and distributors harmless against all claims, costs, damages, and expenses, and reasonable attorney fees arising out of, directly or indirectly, any claim of personal injury or death associated with such unintended or unauthorized use, even if such claim alleges that ON Semiconductor was negligent regarding the design or manufacture of the part. ON Semiconductor is an Equal Opportunity/Affirmative Action Employer. This literature is subject to all applicable copyright laws and is not for resale in any manner.

## PUBLICATION ORDERING INFORMATION

### LITERATURE FULFILLMENT:

Literature Distribution Center for ON Semiconductor  
19521 E. 32nd Pkwy, Aurora, Colorado 80011 USA  
**Phone:** 303-675-2175 or 800-344-3860 Toll Free USA/Canada  
**Fax:** 303-675-2176 or 800-344-3867 Toll Free USA/Canada  
**Email:** [orderlit@onsemi.com](mailto:orderlit@onsemi.com)

**N. American Technical Support:** 800-282-9855 Toll Free  
USA/Canada  
**Europe, Middle East and Africa Technical Support:**  
Phone: 421 33 790 2910  
**Japan Customer Focus Center**  
Phone: 81-3-5817-1050

**ON Semiconductor Website:** [www.onsemi.com](http://www.onsemi.com)  
**Order Literature:** <http://www.onsemi.com/orderlit>  
For additional information, please contact your local  
Sales Representative